



LSWT

Linear Shockwave Therapy for Erectile Dysfunction

Clinical Data and Reports



January 2015



Table of Contents

Initial Experience with Linear Focused Shockwave Treatment for Erectile Dysfunction: a 6-Months Follow-Up Pilot Study	... 4
Y. Reisman, A. Hind, A. Varanekas, I. Motil	
Internation Journal of Impotence Research, October 2014	
Safety and Efficient Duration of Linear Focused Shockwave Treatment for Erectile Dysfunction – A 12 months Follow-up Pilot Study	... 9
Y. Reisman	
16 th World Meeting on Sexual Medicine, Sao Paulo, October 2014	
Initial Clinical Experience of Linear Focused, Low Intensity Shockwave for Treatment of ED Patients with Different Severity Symptoms	... 11
N. Cruz, A. Morales	
16 th World Meeting on Sexual Medicine, Sao Paulo, October 2014	
Efficacy and Safety of Linear Focused Shockwaves for Erectile Dysfunction (RENOVA) – A Second Generation Technology	... 13
Y. Reisman, A. Hind, A. Varanekas, I. Motil	
12 th Congress of Latin American Society for Sexual Medicine (SLAMS), Cancun, August 2013	
Low intensity shock wave (LISW) treatment (Renova) in order to improve male sexual function: A preliminary data on 47 patients	15
F. Iacono, A. Ruffo, D. Prezioso, G. Romeo, E. Illiano, L. Romis, G. Di Lauro	
16 th Congress of the European Society for Sexual Medicine (ESSM), Istanbul, February 2014	
Low Intensity Linear Focused Shockwave Therapy: a New Treatment to Improve the Quality of Life of Vascular Erectile Dysfunction Patients 17
P. Puppo, A. Casarico	
21 st National Congress of the Italian Urology Association, Rome, June 2014	
Linear Low Intensity Shockwaves Treatment of Vasculogenic ED – First Results 20
I. Motil, T. Šramkova	
102 nd Annual Meeting of the Japanese Urological Association (JUA), Kobe, April 2014	

LSWT – CLINICAL DATA AND REPORTS

Efficacy and Safety of Linear Focused Shockwaves for Erectile Dysfunction ... 22
(RENOVA) – A Second Generation Technology

Y. Reisman, A. Hind, A. Varaneckas, I. Motil

2nd Biennial Meeting of the Middle East Society for Sexual Medicine (MESSM),

Dubai, November 2013

Linear Shock Wave Therapy for the Treatment of Erectile Dysfunction 24

M. Pelayo-Nieto et al.

33rd American Confederation of Urology (CAU) Congress, Uruguay, November 2014

Line Focused Shock Wave for Erectile Dysfunction – a different technological 28
approach

A. Hind, O. Saleh, Y. Abu Asbeh

5th Pan Arab Congress of Sexual Medicine, Dubai, April 2013

The Effect of Low Intensity Shockwave Therapy on the Erectile Function of 31
Smokers and Non-smokers - Initial Report with a Dedicated System

P. Puppo, A. Casarico

30th Italian society of Andrology Congress (SIA), Maratea, May 2014



ORIGINAL ARTICLE

Initial experience with linear focused shockwave treatment for erectile dysfunction: a 6-month follow-up pilot study

Y Reisman¹, A Hind², A Varaneckas³ and I Motil⁴

Low-intensity shockwaves (LISW) are known to produce revascularization and have been in evaluation and in use to treat erectile dysfunction (ED). The present single-arm pilot study is aimed to assess the safety and efficacy of a dedicated shockwave device (Renova) on vasculogenic ED patients. Fifty-eight patients with mild to severe ED were treated by LISW and their erectile function was evaluated by the International Index of Erectile Function–Erectile Function Domain (IIEF–EF), Sexual Encounter Profile and Global Assessment Questions questionnaires, at baseline and at 1, 3 and 6 months post treatment. The average IIEF–EF increased significantly from 14.78 at baseline to 21.93 at 3 months post treatment and stabilized at 22.26 at 6 months post treatment. Out of 58 patients, 47 (81%) had a successful treatment. No adverse events were reported during the treatment and the follow-up duration. In conclusion, it suggests that the performance of LISW could add a new advanced treatment for ED.

International Journal of Impotence Research advance online publication, 4 December 2014; doi:10.1038/ijir.2014.41

INTRODUCTION

Vasculogenic erectile dysfunction (ED) is defined as inability to get or keep an erection firm enough for satisfying sexual intercourse and is maybe originated by diseases, such as diabetes mellitus (DM) and atherosclerotic vascular occlusive disease. Current methods for treating vasculogenic ED aim at reducing symptoms instead of reversing the source of the dysfunction, which in the majority of the patients is due to arterial or inflow disorders.¹ It has been demonstrated that shockwaves can enhance intrinsic angiogenesis and are used to treat ischemic heart disease.² Low-intensity shockwaves (LISW) have been evaluated for treating ED in both pilot and randomized sham-controlled studies. The encouraging results that were seen in these studies were the first to show the effect of LISW on ED symptoms,^{3–4} but have never been evaluated elsewhere. Recently published study conducted on rats with DM-associated ED showed that low-energy shockwave therapy (LESWT) significantly restored erectile function to levels almost similar to normal levels of controls. The therapeutic efficacy of LESWT is possibly mediated by increased recruitment of mesenchymal stem cells (MSCs) that promote the regeneration of DM-damaged erectile tissues.⁵

The present study was aimed to assess the safety and efficacy of a new dedicated shockwave device, 'Renova', which was designed to achieve substantially superior organ coverage, compared with the existing devices and hence produces positive results with a shorter protocol in a multicenter study.

SUBJECTS AND METHODS

Study protocol

This study was a multicenter open-label prospective pilot study, conducted at four sites. It was conducted in accordance with the principles of the Declaration of Helsinki of World Medical Association. Patients gave their written informed consent before participation in the study. This study consisted of a screening phase, treatment phase and a 6-month follow-up

phase. At screening phase, patients had an extensive medical and sexological history evaluation, as well as a physical examination. Inclusion criteria were heterosexual men in stable heterosexual relationship for at least 3 months, aged 20–80 years, with vascular ED (according to physician judgment) for at least 6 months, International Index of Erectile Function–Erectile Function Domain (IIEF–EF)⁶ score of 6–25 points. Recruited patients were both responders and nonresponders to phosphodiesterase type 5 inhibitors (PDE5-i). The exclusion criteria were hormonal, neurological or psychological pathology, past radical prostatectomy, any unstable medical or psychiatric condition, spinal cord injury, penile anatomical abnormalities, clinically significant chronic hematological disease, usage of antiandrogens, recovering from cancer in the past 5 years or radiotherapy in pelvic region.

At baseline and follow-up visits IIEF–EF and Sexual Encounter Profile (SEP)—questions 2 and 3 questionnaires were used.^{7–8} Global Assessment Questions⁹ (GAQ) were used at follow-ups as well. The IIEF–EF questionnaire is widely accepted as the best method to verify ED progress. It includes six questions regarding erectile function and its score range is 1–30 points. Safety was assessed at each treatment and follow-up visits, by answering questions regarding side effects and pain as part of the case report form (CRF). Patients were instructed to inform the investigators if any side effects occur.

Almost all of the patients were using PDE5-i during baseline evaluation. No PDE5-i were used 3 weeks prior to treatment, during shockwave treatment, and until the first follow-up, 1 month post-treatment. Answering the questionnaires at the 3 and 6 months post-treatment follow-ups was made, whereas the patients were using PDE5-i, as was done in previously done studies.³ At all follow-up sessions, patients were instructed to return to the exact PDE5-i consumption as at baseline, as shown in Figure 1. Patients committed to avoid using any ED treatment other than PDE5-i oral medication throughout the study duration.

The treatment consisted of 4 weekly treatment sessions. During each session 3600 shocks of 0.09 mJ mm² were applied. Shocks were applied at the penis shaft at right corpus cavernosum and left corpus cavernosum, and at the crura at right crus and left crus, 900 shocks at each area. The treatment areas were the same for each session, so that at the end of the full treatment (four sessions) each area has received 3600 shocks of 0.09 mJ mm².

¹Men's Health Clinic, Amstelland Hospital, Amsterdam, The Netherlands; ²Urology and Andrology Center, Red Crescent Hospital (RCH), Ramallah, Palestine; ³Amber Clinic, Klaipėda, Lithuania and ⁴Urologická ambulance, Brno, Czech Republic. Correspondence: Dr Y Reisman, Urology, Amstelland Hospital, Laan van de Helende Meesters 8, 1187NR Amsterdam, The Netherlands.

E-mail: creisman@planet.nl

Received 28 December 2013; revised 10 July 2014; accepted 18 October 2014

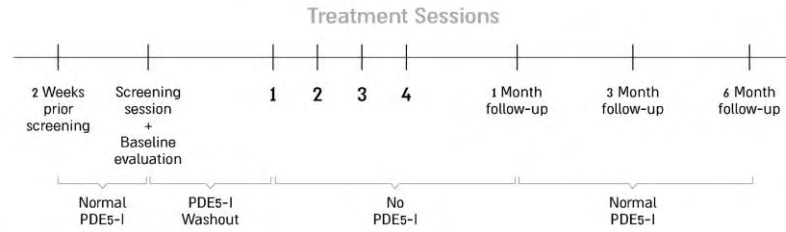

Figure 1. The use of PDE5-I throughout the study.

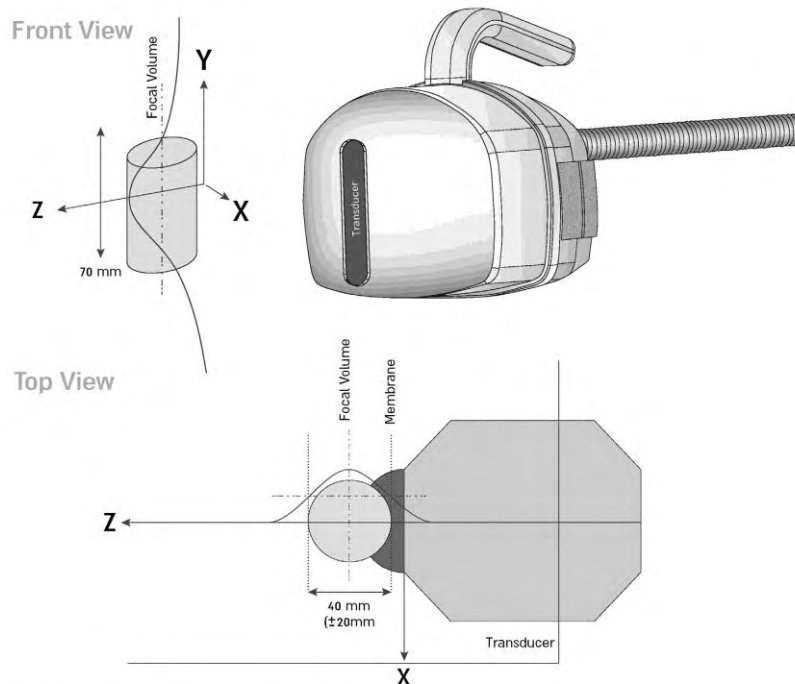

Figure 2. Qualitative view of the shockwave intensity changes.

Follow-ups were conducted at 1, 3 and 6 months post treatment and were consisted of adverse events report, IIEF-EF, SEP and GAQ questionnaires. The primary success criterion, regarding to efficacy, was defined as an increase of IIEF-EF score from baseline to the third follow-up (6 months post treatment) according to the initial ED severity: > 2-point increase for mild symptoms; > 5 points for moderate symptoms; and > 7 points for severe symptoms.⁶

Treatment device

Renova (Direx Group) is the first dedicated shockwave system for ED. Instead of generating shockwaves that converge on a single focal point and require moving the shockwave source to multiple positions along the penis, Renova is based on linear shockwave therapy (LSWT) that enables focusing shockwaves on a 70 mm long and 10 mm width treatment area along the target organ. The shockwaves penetrate into the treated organ to a 40 mm depth and therefore their focal volume is 9.4 cm³. Figure 2 described qualitatively how shockwaves intensity changes in z axis. The prolonged shape of the transducer (Figure 3) enables effective positioning when applying to the crura by its direct contact to the groin. Renova's electromagnetic generator delivers shockwaves with a maximum energy density of 0.09 mJ mm², meaning, they deliver 10% of the pressure used for disintegrating kidney stones. Shocks are delivered at a maximum rate of 300 pulses min⁻¹ (PPM; 5 Hz), therefore, the net treatment time of a session of 3600 shocks lasts ~ 15 min.



Figure 3. Renova's transducer: its prolonged shape enables effective positioning when applied to the crura.

Statistical analysis

Patients' demographic variables were summarized by descriptive statistics. The average score of each questionnaire and its s.d. was calculated at baseline and at 1-, 3- and 6-month follow-up. Student's *t*-test were used at significance level of < 0.05.

RESULTS

Fifty-eight middle-aged men (mean: 56.75 ± 9.91 years, range: 33–84 years) with vasculogenic ED were recruited for this study: 20 patients were treated at Men's Health Clinic, Amstelland Hospital, Amsterdam; 17 were treated at the Urology and Andrology Center,

Red Crescent Hospital, Ramallah; 11 were treated at Amber Clinic, Klaipėda; and 10 were treated in Urologickaambulance.cz, Brno. Patients' characteristics were similar in all sites, excluding the patients in Brno, who had a longer duration of ED and a lower success rate than the rest of the sites. The selection of patients in the Lithuanian site was made with patients who had a milder average of clinical signs.

Twenty-five patients (43.1%) suffered from cardiovascular disease, 41.4% (24 patients) had diabetes, 39.7% (23 patients) suffered from hypertension and 46.6% (27) had high cholesterol level. Fifty patients (86.2%) were PDE5-i responders. In all, 37.9% of patients were smokers, 19.0% were past smokers and 43.1% have never smoked. Table 1 describes patients' background diseases with an emphasis on some of the main risk factors for vasculogenic ED.

Patients' baseline IIEF-EF score ranged between 6 and 25 points with an average of 14.8. Table 2 summarizes the effect of low-intensity extracorporeal shockwave therapy on the IIEF-EF scores, according to the baseline ED severity.

A moderate negative Pearson correlation coefficient of -0.62 was found between the duration of ED and success of treatment. Figure 4 describes the change in the IIEF-EF score between baseline and the follow-ups at 1, 3 and 6 months post treatment, according to the duration of ED. The percentage of patients who have answered 'Yes' to questions 2 and 3 of the SEP was calculated at baseline and at 1-, 3- and 6-month follow-up and is presented in Figure 5.

The percentage of patients who have answered 'Yes' to questions 1 and 2 of the GAQ was calculated at 1-, 3- and 6-month follow-up; for question 1, the percentages were 74.14%, 82.76% and 89.66%, respectively. For question 2, the percentages at 1-, 3- and 6-month follow-up were 63.79%, 68.97% and 75.86%, respectively.

Table 1. Patients' comorbidities with an emphasis on some of the main risk factors for vasculogenic ED: cardiovascular diseases; diabetes; hypertension; and high cholesterol

Disease	Cardiovascular disease	Diabetes	Hypertension	High cholesterol
Prevalence (%)				
27.6				
19.0	✓	✓		✓
10.3			✓	✓
10.3	✓	✓		
8.6		✓		
8.6		✓		✓
6.9		✓	✓	✓
1.7	✓	✓	✓	
1.7	✓			✓
1.7	✓	✓	✓	
1.7	✓	✓		
1.7	✓			

Table 2. The results of the IIEF-EF, before and at 6 months following low-intensity extracorporeal shockwave therapy

Baseline ED severity	Number of patients	PDE5-i responders	Baseline IIEF-EF AVG ± s.d.	IIEF-EF improvement points AVG ± s.d.	% Success	P-value
Severe	13	69.23%	8.5 ± 1.2	8.5 ± 6.3	61.54	< 0.001
Moderate	22	86.36%	13.3 ± 1.8	8.3 ± 5.1	77.27	< 0.001
Mild to moderate	18	94.44%	18.6 ± 1.5	6.8 ± 3.0	94.44	< 0.001
Mild	5	100.00%	23.6 ± 1.3	3.6 ± 0.5	100.00	< 0.001
Total	58	86.2%	14.8 ± 4.8	7.5 ± 4.7	81.03	< 0.001

Abbreviations: ED, erectile dysfunction; IIEF-EF, International Index of Erectile Function-Erectile Function Domain; PDE5-i, phosphodiesterase type 5 inhibitors. Two-tailed *t*-test was performed on the IIEF-EF scores of each group of ED severity before Renova treatment and at 6-month follow-up.

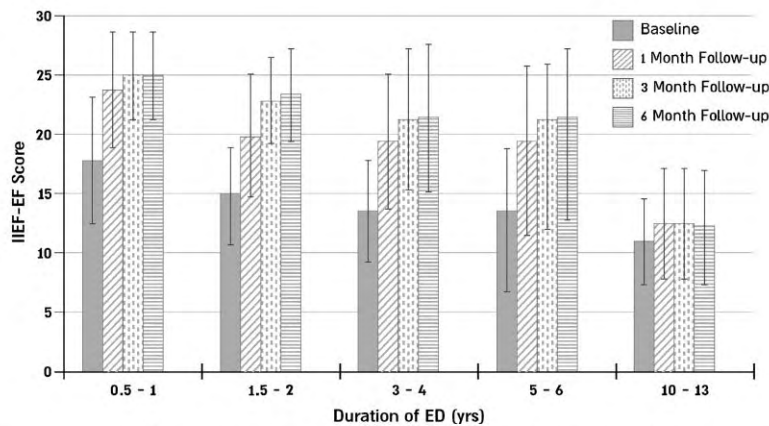

Figure 4. The change in the IIEF-EF score between baseline and the follow-ups at 1, 3 and 6 months post treatment, in accordance with the ranges of ED duration. The error bars indicate the s.d. of each group.

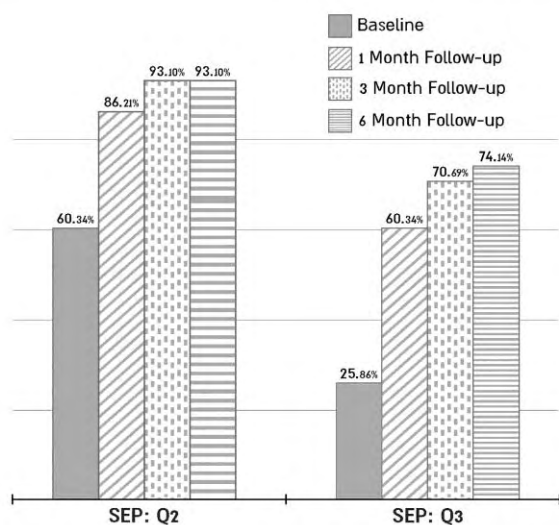

Figure 5. the average results of SEP questions 2 and 3 at the baseline and at each follow-up. The percentages represent the fraction of patients who have answered 'Yes' to each of these questions.

The difference between the IIEF-EF scores and the SEP answers, from baseline to the third follow-up was remarkable and has a statistical significance, with a *P*-value of < 0.001 .

LISW treatment has succeeded in $>80\%$ of the cases (47 patients). Among the successful patients, the average IIEF-EF score increase was nine points.

When comparing diabetic patients and nondiabetic patients, the success rate of the latter group was 25% higher (70.83% and 88.24%, respectively). In all, 41.4% of patients in this study were diabetic (24 patients) and there was no significant difference between age and ED duration of the diabetic and nondiabetic patients (57.45 and 56.25 years, 2.90 and 2.96 years, respectively). This may indicate on better suitability of this treatment to nondiabetic patients.

Among the 58 patients, 4 patients stopped using PDE5-i during follow-up as they had no need for it.

No adverse events or complications were reported during and following treatment.

During the treatment period and thereafter, no use of analgesics was needed.

DISCUSSION

This study is the first study that shows a successful treatment with LISW for vascular ED in a multicenter manner, which is not connected to the previous publications and from different sites than the previous publications.³⁻⁴

When compared with previously described studies, in which PDE5-i were used, the results of this study are in line, with similar success rates.³⁻⁴

This study included patients with mild to severe ED symptoms, whereas 22.4% of patients had severe symptoms, 37.9% moderate, 31.0% mild to moderate and 8.6% mild. The average baseline IIEF-EF was 14.8 points, which represents moderate ED symptoms.

When comparing the success rate between groups of other comorbidities, no strong correlation was found. Owing to the small sample size, more research is required.

Almost 28% of the patients didn't have any of the following vascular ED risk factors: cardiovascular disease; diabetes; hypertension; and high cholesterol. The success rate of patients who

had at least one of the diseases listed above was 76.2%, whereas the success rate of patients without any of these diseases was 93.7%. There were no significant differences between the age, duration of ED and percentage of PDE5-i responders between patients with at least one of the listed disease and patients without any of these diseases (57.3 and 55.3 years, 3.0 and 2.7 years, 85.7% and 87.5%, respectively). The percentage of smokers was higher in the group of patients without any of the listed diseases (62.5%) compared with the second group (54.8%). Out of the first group, all patients who were nonsmokers (10.3% of all patients) succeeded in the treatment.

The ED duration of failed patients was on average longer than the ED duration of the whole group, with 6.4 and 2.9 years, respectively. As seen in Figure 3, the increase in IIEF-EF score decreases as the ED duration rises. Satisfactory success rates were shown in cases of ED that started up to 10 years previously, and even higher success rates were demonstrated on patients who recently noticed a decrease in erectile function. The average results are very disappointing for patients with ED for > 10 years, so it seems this treatment is not adequate for such patients whereas average results are satisfactory for patients with ED for 5-6 years or less.

A comprehensive research is required for designing a modified protocol that would be suitable for cases of longtime ED.

When considering the numerical change in IIEF-EF, only six patients (10%) have not experienced any change in their erectile function.

When reviewing the change in SEP scores, a significant increase between baseline and follow-up is noticeable. These questions can indicate directly on the patients erectile function condition, as they are referring directly to the patient's ability to perform successful intercourse.

When reviewing the individual answers for the GAQ questionnaires, it appears that 75% of the patients (44 patients) have answered 'Yes' to both questions. As these questions are intended to evaluate the treatment, these results indicate a successful treatment and support the results found with the IIEF-EF scores.

When looking at the percentage of almost 7% of patients who stopped using PDE5-i after the treatment, this could perhaps be one of the next steps in the development of this treatment option, and might be a viable option for patients who are not satisfied with the effect of PDE5-i or that these drugs are contraindicated for them.

The specifically designed device, which has a specialized transducer that is configured to reach the exact treated areas, is able to treat a bigger area than other previously used devices and therefore enables a better adjustment to the patient's body, a shorter duration of treatment and a better coverage.

This pilot study on a small number of ED patients with a relatively short follow-up shows encouraging results. Large multicenter, long-term, randomized and sham-controlled studies are needed to be able to evaluate and define those patients who respond to this type of treatment. More data are also needed with regard to the possible long-term impact of shockwaves on penile tissue. More basic research is needed to be able to understand the mechanism of action of LISW on tissues.

CONCLUSIONS

The initial results of this pilot study suggest positive outcomes of this second generation technology for treating ED with linear low-intensity shockwaves. This study with 6 months follow-up from almost 60 patients is suggestive of a positive therapeutic efficiency in the majority of the patients. Pain is tolerated by 100% of the treated patients and no side effects have been recorded, demonstrating the potential of this technology, as a treatment option for men who are not satisfied by the currently available solutions.

**CONFLICT OF INTEREST**

The authors declare no conflict of interest.

ACKNOWLEDGMENTS

Direx Group provided the treatment device (Renova), which generates linear focused shockwave.

REFERENCES

- 1 Stief C *et al*. Physiology and pathophysiology of men's sexual arousal and penile erection. In: Montorsi F *et al*. (eds). *Sexual Medicine Sexual Dysfunctions in Men and Women. 3rd International Consultation on Sexual Medicine*. Health Publication Ltd: Paris, 2010, pp 605–680.
- 2 Ito K, Fukumoto Y, Shimokawa H. Extracorporeal shock wave therapy as a new and non-invasive angiogenic strategy. *Tohoku J Exp Med* 2009; **219**: 1–9.
- 3 Vardi Y, Appel B, Jacob G, Massarwi O, Gruenwald I. Can low-intensity extracorporeal shockwave therapy improve erectile function? A 6-month follow-up pilot study in patients with organic erectile dysfunction. *Eur Urol* 2010; **58**: 243–248.
- 4 Vardi Y, Appel B, Kilchevsky A, Gruenwald I. Does low intensity extracorporeal shock wave therapy have a physiological effect on erectile function? Short-term results of a randomized, double-blind, sham controlled study. *J Urol* 2012; **187**: 1769–1775.
- 5 Qiu X. Effects of low-energy shockwave therapy on the erectile function and tissue of a diabetic rat model. *J Sex Med* 2013; **10**: 738–746.
- 6 Rosen RC, Allen KR, Ni X, Araujo AB. Minimal clinically important differences in the erectile function domain of the International Index of Erectile Function scale. *Eur Urol* 2011; **60**: 1010–1016.
- 7 Rosen RC, Cappelleri JC, Gendrano N 3rd. The International Index of Erectile Function (IIEF): a state-of-the-science review. *Int J Impot Res* 2002; **14**: 226–244.
- 8 Hatzichristou D *et al*. Clinical evaluation and symptoms scales in men and women with sexual dysfunction. In: Montorsi F *et al*. (eds). *Sexual Medicine Sexual Dysfunctions in Men and Women. 3rd International Consultation on Sexual Medicine*. Health Publication Ltd: Paris, 2010, pp 229–280.
- 9 Porst H *et al*. Standards for clinical trials in male sexual dysfunctions. In: Montorsi F *et al*. (eds). *Sexual Medicine Sexual Dysfunctions in Men and Women. 3rd International Consultation on Sexual Medicine*. Health Publication Ltd: Paris, 2010, pp 567–603.



Safety and Efficient Duration of Linear Focused Shockwave Treatment for Erectile Dysfunction – A 12 months Follow-up Pilot Study

Y. Reisman

Men's Health Clinic, Bovenij Hospital, Amsterdam, The Netherlands

Objective

The aim of this pilot study was to assess the safety, effectiveness and sustainable results of the Linear Focused Shockwave system Renova, for the treatment of Vascular Erectile Dysfunction patients.

Material and methods

Renova is a system that uses a Linear Low Intensity Shockwave technology. We have treated 20 patients with Vasculogenic ED; with an averaged International Index of Erectile Function (IIEF-EF) score of 12.35 ± 3.16 (Range 7-18). The protocol consisted of 4 weekly sessions, in which a total of 3600 shockwaves were applied, divided into 4 areas; right and left crura, and right and left corpus cavernosum, 900 shockwaves in each site. The following questionnaires were used: IIEF-EF, Sexual Encounter Profile (SEP) and Global Assessment Question (GAQ), at baseline visit and 1, 3, 6 and 12 months post treatment. Success was defined as an increase in score from baseline to the 6 months post treatment follow-up, according to Minimal Clinical Improvement Criteria (Rosen et al.).

Results

At the 6 months follow-up, 18 patients out of 20 showed success (90%). Out of these 90%, **83.3% (15 patients) sustained the positive outcome for a period longer than 12 months** after the end of treatment. The average IIEF-EF increased significantly from 12.35 ± 3.16 at baseline to 20.65 ± 2.64 at 6 months post treatment, and was 18.65 ± 2.56 at the 12 month follow-up. Four patients (20%) who were non-responsive to Phosphodiesterase type 5

LSWT – CLINICAL DATA AND REPORTS

Inhibitors (PDE5i) at baseline became responsive after the treatment, and 2 patients (10%) successfully stopped using PDE5i. All 20 patients completed the last follow-up with an average of 14.5 ± 1.08 months duration from the end of treatment. Among the successful patients, the average IIEF-EF score increase was 8.3 points. No side effects were reported.

Conclusions

With a success rate of 90% after 6 months, and an 83.3% sustainable positive effect after 1 year, the results of this pilot study suggest that this treatment is probably effective for at least 1 year. No anaesthesia or analgesia was needed, and no adverse effects were recorded, making it a potential good alternative for current available treatments.

The above paper abstract was presented at the 16th World Meeting on Sexual Medicine, on October 11th 2014, Sao-Paulo, Brazil.



Initial Clinical Experience of Linear Focused, Low Intensity Shockwave for Treatment of ED Patients with Different Severity Symptoms

N. Cruz¹, A. Morales²

¹Clinica Andromedi Sevilla, ²Instituto de Urología Málaga

Objective

The aim of this clinical experience was to assess the feasibility of the application of Linear Focused Low Intensity Shockwaves (Renova Direx Group) as an alternative or complementary treatment for Vascular ED patients with different degrees of symptom severity.

Material and methods

The treatment was offered in a routine natural way in 2 medical centers: 46 patients in Malaga (series A), and 35 in Sevilla (Series B). The treatment was composed of 4 weekly sessions, in which shockwaves were applied into 4 areas: right and left crura, and right and left corpus cavernosum, with 900 shockwaves in each site (Total 14400). No need for anesthesia, sedation or painkillers and each session's treatment time was 20 minutes. The evaluation was done using the IIEF-EF, SEP and GAQ questionnaires, at baseline visit, 1 month and 3 months post treatment.

Results

The average IIEF-EF increased significantly from 19.94 and 14.03 at baseline to 23.92 and 18.53 at 3 months post treatment. A number of patients stopped using PDE5-i; 30.77% and 23.53% respectively. SEP 2 increased from 88.89% and 43.48% to 100% and 66.67%. The SEP 3 increased from 38.89% and 27.59% to 78.75% and 57.89%.

LSWT – CLINICAL DATA AND REPORTS

At baseline, the use of PDE5-i for sexual intercourses was needed by 77.78% and 85.19% of patients, and was reduced to 53.85% and 35.29% at 3 months post treatment. No side effects were recorded.

Conclusions

The results of both series at 3 months show a consistent and global improvement in IIEF-EF, SEP 2 and SEP 3 parameters. Since the baseline symptoms severity of patients in series B was much higher compared to series A, the end results obtained in series B are consistently lower compared to series A.

This would imply that the outcome of the treatment is related to the baseline symptoms severity, meaning that in average, patients with more severe ED symptoms will improve, but will not reach the final level of improvement that can be obtained by mild to moderate patients. In our experience the Linear-Focused Low Intensity Shockwave treatment is a valid alternative or complement to current available treatments.

The above paper abstract was presented at the 16th World Meeting on Sexual Medicine, on October 11th 2014, Sao-Paulo, Brazil.



Efficacy and Safety of Linear Focused Shockwaves for Erectile Dysfunction (RENOVA) – A Second Generation Technology

Y. Reisman¹, A. Hind², A. Varaneckas³, I. Motil⁴

¹Men's Health Clinic, Bovenij Hospital, Amsterdam, The Netherlands, ²Urology and Andrology Center, Red Crescent Hospital (RCH), Ramallah, Palestine, ³Amber Clinic, Klaipėda, Lithuania, ⁴Uroclinic Brno, Brno, Czech Republic

Introduction

Recent studies have demonstrated that low intensity shockwaves have a therapeutic effect on ED of vascular origin.

Objective

The present study was aimed to assess the efficacy and safety of a dedicated shockwave device, Renova, which was designed to achieve substantially superior organ coverage.

Material and Methods

52 patients with mild to severe ED were treated by Renova as part of a multi-center, open-label, prospective pilot study, conducted at 4 sites. Patients underwent 4 weekly treatment sessions by a Renova that generates line focused shockwaves. Patients' erectile function was assessed by the IIEF-EF, SEP and GAQ questionnaires at baseline and at 1 and 3 months post treatment. Success was defined as an increase of IIEF-EF score from baseline to the second follow up according to the severity of the symptoms at baseline.

Results

The average IIEF-EF greatly increased from 14.7 at baseline to 21.4 at 1 month and 3 months post treatment. **Out of 52 patients, 41 (79%) had a successful treatment.** No adverse events

LSWT – CLINICAL DATA AND REPORTS

were reported during the treatment and the follow-up duration. Main outcomes are presented in the following table:

Age	Baseline IIEF- EF	Improvement in IIEF- EF	P value	% Success
57.2 ± 10.1	14.7 ± 4.9	6.8	<0.0001	78.8%

Conclusions

The results of this study indicate success of the second generation technology for treating ED with linear low-intensity shockwaves. Initial follow up data demonstrate a therapeutic success in almost 80% of patients. No side effects have been recorded, demonstrating the suitability of this treatment in an office setting.

The above paper abstract was presented at the 12th Congress of the Latin American Society for Sexual Medicine, on August 29th 2013, Cancun, Mexico.



Low intensity shock wave (LISW) treatment (Renova) to improve male sexual function: A preliminary data on 42 patients

F. Iacono, A. Ruffo, D. Prezioso, G. Romeo, E. Illiano, L. Romis, G. Di Lauro
Centro Urolab, Napoli, Italy

Objective

The aim of our study is to investigate the safety and efficacy of Low intensity Extracorporeal shock wave therapy LI-ESWT (Renova) in the treatment of erectile dysfunction.

Methods

We enrolled 47 patients with erectile dysfunction (ED). They underwent four weekly sessions using a dedicated device (Renova) for the management of erectile dysfunction. The treatment included four weekly sessions. During each treatment session, LI-ESWT was applied at four different anatomical areas, right and left corpus cavernosum and right and left crus penis (900 shocks, 0.09 mJ/mm² intensity at 240 shocks/min at each site for a total of 3600 shocks). Patients were followed at one month after treatment. Two self-administered questionnaires: International Index of Erectile Function-Erectile Function (IIEF-ED), Sexual Encounter Profile (SEP- Questions 2 and 3) were given to patients to assess their sexual function pre and post treatment.

Results

Five patients dropped out of treatment, so forty-two patients (mean age was 59.2 years) were evaluated. At one month follow-up, we noticed a statistically significant improvement in IIEF-ED domain scores in treated patients (from a mean of 12+/- 4.8 at baseline to 23.5+/- 5.3, $p < 0.05$). **SEP-Q2 and SEP-Q3 success rates improved from 57% to 84% and from 24% to 76% respectively.** No side effects were reported.

LSWT – CLINICAL DATA AND REPORTS

Conclusion

(LI) ESWT improves male sexual function inducing neovascularization in the treated tissues by stimulating the expression of angiogenesis-related growth factors, such as endothelial nitric oxide synthase, vascular endothelial growth factor, and endothelial cell proliferation factors, such as proliferating cell nuclear antigen. This therapy shows a statistically significant clinical improvement of erectile function without any side effect or contraindication. In our opinion further studies are needed even to assess the possibility to repeat the treatment cyclically or in association with PDE5-i or with nutraceutical composite.

The above paper abstract was presented at the 16th Congress of the European Society for Sexual Medicine (ESSM), on February 1st 2014, Istanbul.



Low Intensity Linear Focused Shockwave Therapy: a New Treatment to Improve the Quality of Life of Vascular Erectile Dysfunction Patients

P. Puppo, A. Casarico

Montallegro Clinic, Genova, Italy

Objective

Erectile dysfunction is a common medical disorder that primarily affects men older than 40 years of age. Phosphodiesterase type 5 inhibitors (PDE5i) are considered as first-line therapy as they increase arterial blood flow leading to smooth muscle relaxation, vasodilatation and penile erection. The limitation in the efficacy of PDE5 inhibitors is that a 'critical amount' of NO is necessary for these drugs to work. Therefore, in cases of impairment in NO synthesis or release or in cases of destruction of NO, PDE5 inhibitors cannot cure erectile dysfunction (ED) symptoms.

The correlation between potency and quality of life was established by a study on 1680 men seeking medical attention in a free screening program at three different locations in the USA. Unsurprisingly, it was reported that potent men have a better quality of life than impotent men.

Lately, studies have started to evaluate the effect of low intensity shockwave (LISW) to treat ED on PDE5i responders and non-responders patients.

The current study evaluated how the therapy by a new device ('RENOVA', Initia Ltd, Israel) using low-intensity linear focused shockwave affects the quality of life of patients who suffer from ED of vascular origin and experience full, partial or no response at all to PDE5 inhibitors.

Methods and results

This study was conducted in an outpatient clinic over a period of 10 months. Eligible patients were those who have been suffering from Vasculogenic ED for at least 6 months, and their International Index of Erectile Function score in the erectile function domain (IIEF-EF) was

LSWT – CLINICAL DATA AND REPORTS

between 9 and 25. Patients who had hormonal, neurological or psychological pathology or have undergone radical prostatectomy were excluded.

The treatment consisted of 4 weekly sessions; in each session 4 areas were treated consecutively: left and right sides of the Crura and the Corpora Cavernosa. Shockwaves were delivered with a maximum energy of 0.09mJ/mm²; therefore, no anesthesia was required. During the treatment period (22 days) and 3 weeks prior it, no phosphodiesterase type 5 inhibitors (PDE5-I) were used.

Erectile function was evaluated by means of IIEF-EF, questions 2-3 of the Sexual Encounter Profile (SEP), questions 1-2 of the Global Assessment Questions (GAQ) and the Erection Hardness Score (EHS), at baseline and at 1, 3 and 6 months post treatment. Success was defined as positive answer to both SEP and GAQ questions, EHS of 3 or higher and an increase of IIEF-EF score from baseline to the third follow up (6 months post treatment) according to the severity of the symptoms.

Out of 25 patients who were enrolled to this study, 24 have finished the full treatment series. The mean age of these patients was 62.58 ± 8.32 (45-74) years and the mean duration of their ED was 4.84 ± 4.46 (1-20) years. 52% were smokers, 26% had diabetes, 58% had high cholesterol levels, 37% had a cardiovascular disease and 47% had hypertension. 74% of the patients had a positive response to PDE5 inhibitors.

All patients were instructed to use PDE5 inhibitors during the 4 weeks prior baseline evaluation. At the end of the treatment and during the follow-up period patients were using PDE5 inhibitors as needed.

At the most recent follow-up of each patient, 40% of the PDE5i non-responders and 78% of the responders achieved positive outcomes at all 4 evaluation questionnaires. 42.8% of the responders stopped using PDE5 inhibitors at 6 month follow-up. Out of these patients, 83% achieved positive outcomes at all 4 evaluation questionnaires. **The overall percentage of patients who achieved positive outcomes at all 4 evaluation questionnaires was 70%.** None of the patients have reported on pain during or after treatment. No adverse events were reported.

Discussion

This pilot study was designed for assessing the efficacy of a novel device dedicated for the treatment of erectile dysfunction and based on an original technology that enables the delivery of low-intensity shockwaves onto a long focal area. The subjects in this study included also patients with multiple co-morbidities, different degrees of response to PDE5 inhibitors and wide range of ED severities. The results of this study demonstrate a possible alternative

LSWT – CLINICAL DATA AND REPORTS

treatment for some of the patients who did not respond to first-line oral pharmacotherapy and thanks to this treatment may avoid turning to other therapy options which are less convenient to use. In parallel, these data imply on a potential mean to eliminate the need for PDE5 inhibitors which may significantly improve patients' quality of life. In order to establish the overall effect of this treatment on the quality of life of ED patients, a larger study with longer follow-up duration is required.

The above paper abstract was presented at the 21st National Congress of the Italian Urology Association, on June 2014, Rome, Italy.



Linear Low Intensity Shockwaves Treatment of Vasculogenic ED – First Results

Motil¹, T. Šramkova²

¹Urology Ajem, Brno, Czech Republic, ²Department of Sexology, Brno University Hospital, Czech Republic

Introduction and Objectives

ED is significantly associated with: increased age, diabetes, cardiovascular disease, hypertension, depression, smoking, medications, and has a multifactorial etiology with physical and psychological factors.

The treatment options currently offered to patients are: drugs that reversibly inhibit penile-specific PDE5 and enhance the nitric oxide–cyclic GMP pathways of cavernous smooth muscle relaxation, vacuum constriction device, intraurethral and intracorporeal alprostadil, or surgical treatment-implantation of penile prosthesis.

Our aim was to assess the safety and efficacy of a unique Linear Shockwave Therapy for Vasculogenic ED patients in a prospective trial (PT).

Materials and Methods

22 men with vasculogenic ED completed this open-label, prospective pilot study. In order to compare our own results (22 men) we included the outputs of 3 other European LSWT centers. Finally, an overall of 69 (22+47) patients with mild to severe ED were treated using the Renova device and were evaluated.

The evaluation of success was made according to the IIEF-EF questionnaire, which was filled at baseline, and 1, 3 and 6 months post treatment.

LSWT – CLINICAL DATA AND REPORTS

Results

The average IIEF-EF increased significantly from 14.7 at baseline to 21.6 at 1 month and 3 months post treatment. **82% of patients had a successful treatment.** No adverse events were reported during the treatment and the follow-up duration.

Conclusions

We have been able to prove that Linear SWT is an effective therapeutic option for men with erectile dysfunction of vasculogenic origin. Moreover the efficacy of linear application of low-intensity extracorporeal shock waves is superior to former non-linear methods.

The above paper abstract was presented at the *102nd Annual Meeting of the Japanese Urological Association (JUA)*, on April 21st 2014, Kobe, Japan.



Efficacy and Safety of Linear Focused Shockwaves for Erectile Dysfunction (RENOVA) – A Second Generation Technology

Y. Reisman¹, A. Hind², A. Varaneckas³, I. Motil⁴

¹Men's Health Clinic, Bovenij Hospital, Amsterdam, The Netherlands, ²Urology and Andrology Center, Red Crescent Hospital (RCH), Ramallah, Palestine, ³Amber Clinic, Klaipėda, Lithuania, ⁴Uroclinic Brno, Brno, Czech Republic

Introduction

Vasculogenic erectile dysfunction (ED) which is caused by arteriosclerosis can be treated by a variety of therapies that aim at reducing ED symptoms. Low-intensity shockwaves (LISW) were discovered as an enhancing factor to angiogenesis for treating ischemic heart disease. In addition, LISW therapy demonstrated significantly the restoration of erectile function in diabetic rats. The present study evaluates the therapeutic effect of LISW produced by an innovative device on patients with erectile dysfunction.

Objective

The present study was aimed to assess the safety and efficacy of a dedicated shockwave device, 'Renova', which was designed to achieve substantially superior organ coverage.

Material and Methods

57 patients with mild to severe ED were treated by Renova as part of a multi-center, open-label, prospective pilot study, conducted at 4 sites. Patients underwent 4 weekly treatment sessions by a novel machine (Renova) that generates line focused shockwaves at 4 treated areas: right and left crus and right and left corpus cavernosum. Each treatment session lasted approximately 15 minutes, did not required anesthesia and did not cause any pain or adverse effects. Patients' erectile function was assessed by the IIEF-EF, SEP and GAQ questionnaires

LSWT – CLINICAL DATA AND REPORTS

at baseline and at 1 and 3 months post treatment. Success was defined as an increase of IIEF-EF score from baseline to the second follow up according to the severity of ED symptoms at baseline.

Results

The average IIEF-EF score has greatly increased from 14.7 at baseline to 21.6 at 1 month and 3 months post treatment. **Out of 57 patients, 47 (82%) had a successful treatment.** Among the successful patients, the average IIEF-EF score increase was 8 points. No adverse events were reported during the treatment and the follow-up duration.

Conclusions

The results of this study indicate success of the second generation technology for treating ED with linear low-intensity shockwaves. Initial follow up data from almost 60 patients demonstrate a clear therapeutic success in 82% of patients.

The above paper abstract was presented at the 2nd Biennial Meeting of the Middle East Society for Sexual Medicine, on November 2013, Dubai.



Linear Shock Wave Therapy for the Treatment of Erectile Dysfunction

M. Pelayo Nieto, E. Linden Castro

Centro Médico Nacional 20 de Noviembre México, D.F

Introduction

Linear Shock Wave Therapy (LSWT) is a new non-invasive therapy that uses shock waves of low intensity to induce controlled angiogenesis locally, and significantly improves the hemodynamic function of the male sexual organ.

Objective

To report our experience with the use of Linear Shock Wave Therapy as a treatment for Erectile Dysfunction (ED).

To evaluate the possible effectiveness and safety of LSWT treatment in men with vasculogenic ED.

Material & Methods

This was a Pilot, prospective study. 15 men in the ages of 45-70 years old, sexually active with mild and moderate vasculogenic ED, were evaluated with the International Index of Erectile Function (IIEF-EF). The study was conducted in three stages:

1. Screening: clinical data and examination

Collected data comprised the following: Age, Body Mass Index (BMI), International Prostate Symptom Score (IPSS), Quality of Life according to urinary Symptoms (QoL), Years with ED, Confidence to achieve and maintain Erection (Q15- IIEF-5), Smoking history, Diabetes Mellitus (DM), Hypertension, Ischemic Heart Disease, Baseline IIEF (ED degree), EHS (Erection Hardness Score), SEP Baseline (Sexual Encounter Profile).

LSWT – CLINICAL DATA AND REPORTS

2. Treatment: 4 sessions of LSWT and rehabilitation.

Patients received 4 weekly sessions of LSWT (Renova) with 5000 shocks of 0.09 mJ/mm² intensity, at a rate of 300 shockwaves/min (5Hz), on an area of 60mm long and 40mm deep. Shockwaves were divided into 4 areas (right and left corpus cavernosum received 900 shockwaves on each side, and right and left crus received 1600 shockwaves on each side). Each session lasted 20 min with one week interval between each session. The treatment was performed on an outpatient basis and without the need of anesthesia.

The second phase of treatment consisted of "Rehabilitation" at home between sessions (sexual activity with a partner or manual stimulation).

3. Follow up: Erectile function was assessed by IIEF, EHS, SEP and GAQ (Global Assessment Questions) one month and three months after treatment completion.

Results

Test	Baseline Score	Score after treatment	p Value
IIEF	15 (11-18)	20 (11-23)	p<0.013
EHS	2(2-3)	4 (2- 4)	p<0.01
SEP III	7 patients	12 patients	p<0.0013
GAQ	-	12 patients	

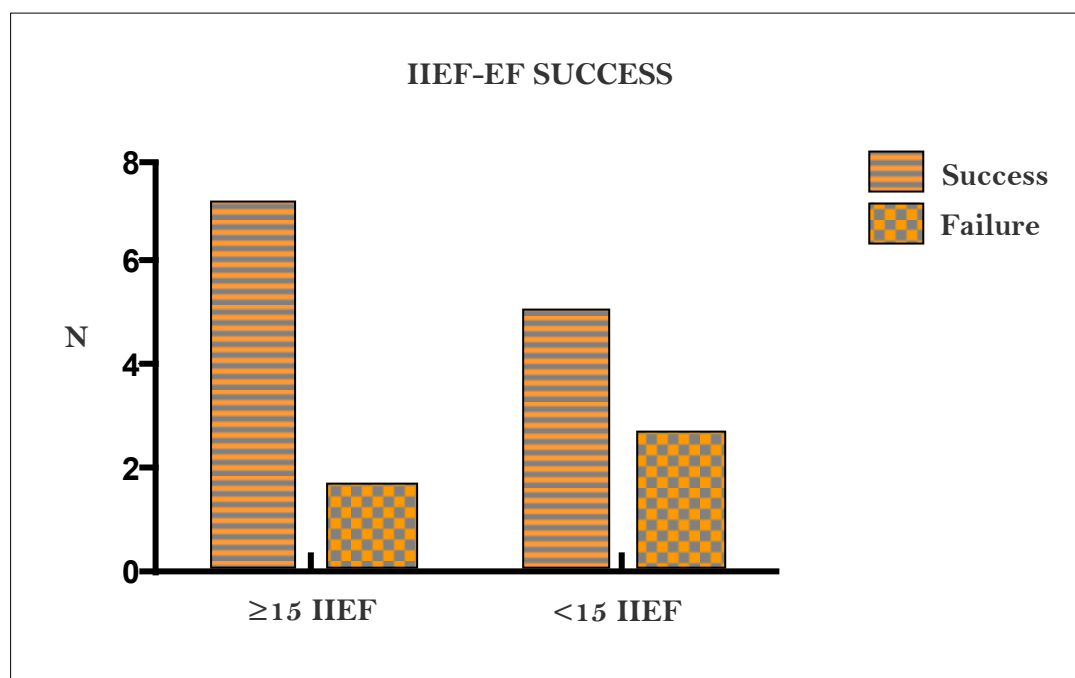

Most successful for patients with mild and mild to moderate symptoms.

LSWT – CLINICAL DATA AND REPORTS

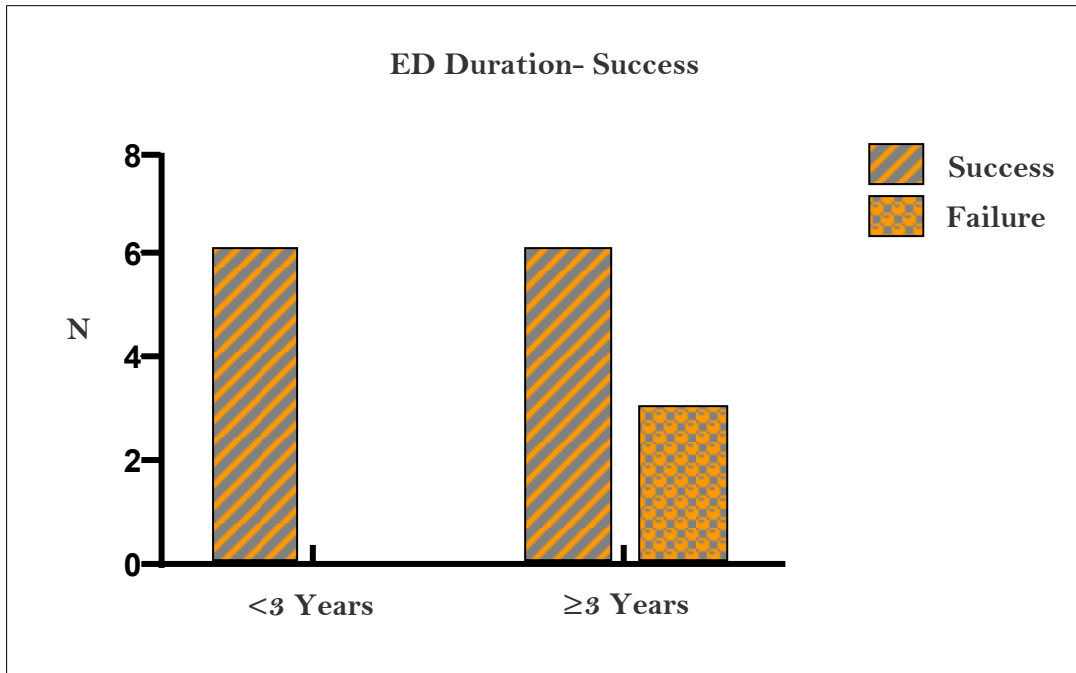

Higher success for patients with a shorter ED duration

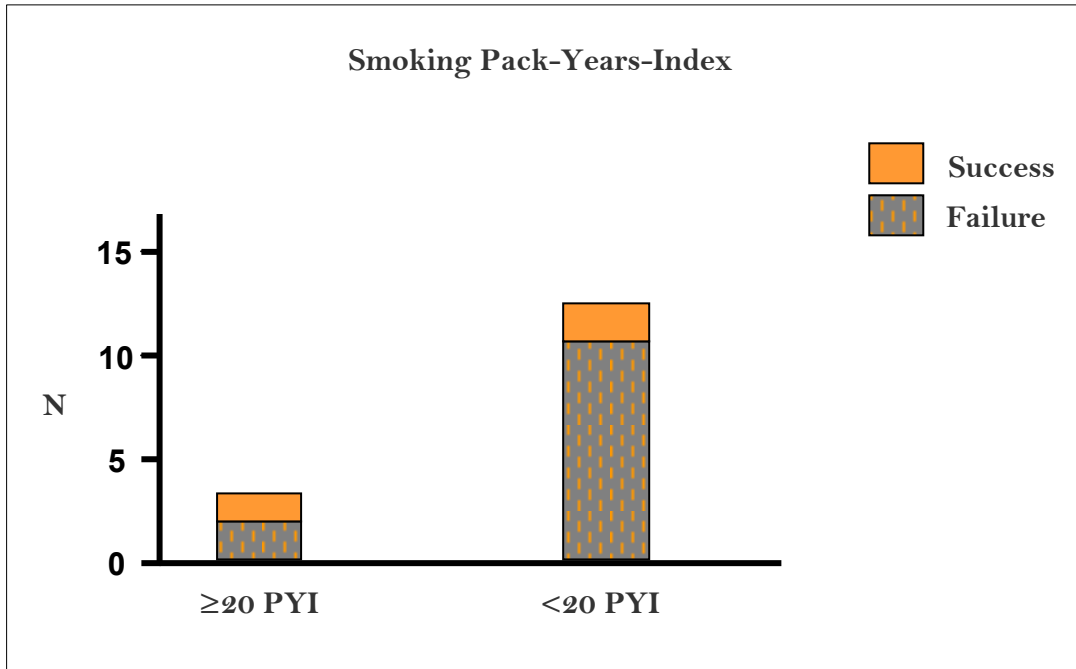

Higher success for patients with a Pack-Years-Index less than 20

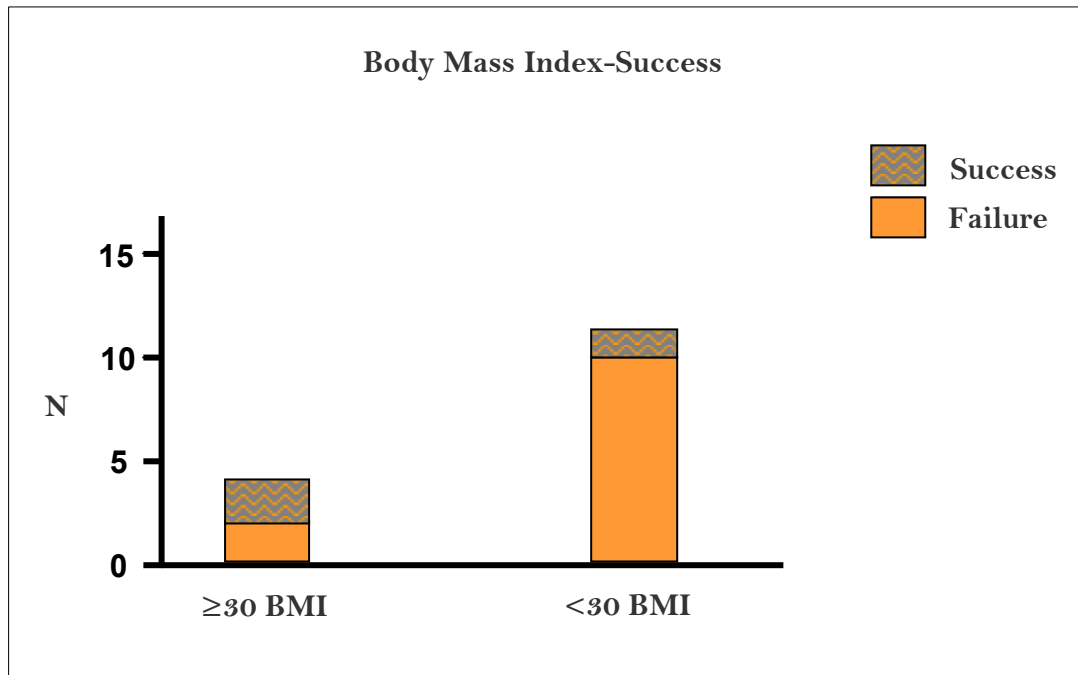

Higher success for patients with a BMI of less than 30

Conclusions

Our short-term results are encouraging but demand a long-term evaluation.

Based on our results, LSWT can be an effective and safe alternative for the treatment of vasculogenic ED. The feasibility and tolerability of this treatment, and rehabilitation potential features, make it an attractive new therapeutic option for patients with vasculogenic ED.

The above paper abstract was presented at the 33rd American Confederation of Urology Congress, on November 24th 2014, Punta del Este, Uruguay.

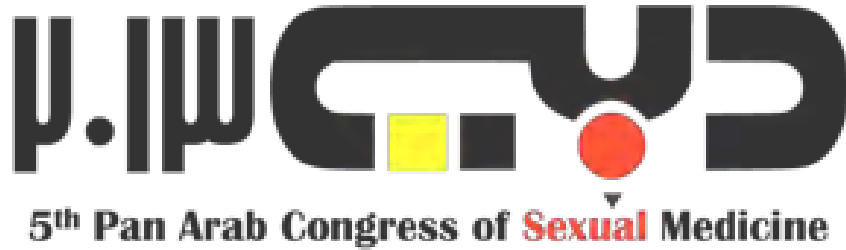

Line Focused Shockwave for Erectile Dysfunction – A Different Technological Approach

A. Hind, O. Saleh, Y. Abu Asbeh

Urology and Andrology Center, Red Crescent Hospital (RCH), Ramallah, Palestine

Introduction

During the last 2 years a new technology was introduced to treat Erectile Dysfunction. The treatment uses Low Intensity Shockwave which was shown to produce angiogenesis in order to improve the patient erectile function for patients of Vasculogenic origin ED. The initial treatments were done with conventional orthopedic treatment shockwave devices, and although results were encouraging, they have a series of limitations.

We are presenting our initial results with a new type of Low Intensity shockwave system that was specifically developed to treat ED.

Patients and Methods

Instead of focusing the shockwave into a focal point, like in any conventional lithotripter, Renova system (DirexGroup) shockwaves focalize along a 70mm line, with a dept of 40mm. This allows a perfect coverage of the full penis shaft and the crura. We use a short protocol of 4 weekly sessions, applying 900 shocks in each of the 4 following areas: right Crus, left Crus, right Corpus Cavernosum, left Corpus Cavernosum.

We have treated 20 patients and we have a follow up of the first 12 patients, both PDE5-I Responders and non Responders.

Results

IIEF-EF: International Index of Erectile Function – Erectile Function Domain

LSWT – CLINICAL DATA AND REPORTS

	Patient Initials	Baseline IIEF-EF	IIEF-EF at 1 month	IIEF Difference	Success /Failure
1	M I M	9	18	9	Success
2	H I S	8	8	0	Failure
3	N M M	8	8	0	Failure
4	J H S	17	24	7	Success
5	M N S	14	25	11	Success
6	O I S	19	25	6	Success
7	M M K	11	24	13	Success
8	A A D	6	19	13	Success
9	I H A	19	28	9	Success
10	A H	19	28	9	Success
11	S A	12	20	8	Success
12	A M H	17	24	7	Success
Average		13.25	20.92	7.67	84%

SEP- Sexual Encounter Profile

	Patient Initials	Baseline		Follow-up	
		SEP 2	SEP 3	SEP 2	SEP 3
1	M I M	NO	NO	YES	YES
2	H I S	NO	NO	NO	NO
3	N M M	NO	NO	NO	NO
4	J H S	YES	YES	YES	YES
5	M N S	YES	NO	YES	YES
6	O I S	YES	YES	YES	YES
7	M M K	NO	NO	YES	YES
8	A A D	NO	NO	YES	YES
9	I H A	YES	NO	YES	YES
10	A H	YES	YES	YES	YES
11	S A	NO	NO	YES	YES
12	A M H	YES	YES	YES	YES
Average		50%	33%	83%	83%

LSWT – CLINICAL DATA AND REPORTS

Comparative follow up: 1 and 3 months

	Patients Initials	Response to PDE5-I	IIEF Score			Results Comparison	Delta	Success
			Baseline	1month	3 months			
1	M I M	YES	9	18	18	Same	9	Yes
2	H I S	NO	9	8	8	Same	-1	No
3	N M M	NO	8	8	8	Same	0	No
4	J H S	YES	17	24	24	Same	6	Yes
5	M N S	YES	14	25	30	Improvement	16	Yes
6	O I S	YES	19	25	25	Same	6	Yes
7	M M K	YES	11	24	24	Same	13	Yes
8	A A D	NO	6	19	19	Same	13	Yes
9	I H A	YES	19	28	28	Same	7	Yes
10	A H	YES	19	28	28	Same	7	Yes
11	S A I	YES	12	20	20	Same	8	Yes
12	A M H	YES	17	24	24	Same	7	Yes

- Results at 1 and 3 month follow-up are essentially the same.
- Successful results are seen at 1 month post treatment.

Conclusions

- Initial results at 1 and 3 months show great progress in erectile function.
- Average IIEF-EF increased from 13.25 to 20.92 (57.86 % improvement).
- **84% Success according to success criteria.**
- All mild to moderate cases have succeeded.
- One severe case has improved while 2 severe cases failed.
- SEP and GAQ results have improved.
- No pain and no complications were reported.

The above paper abstract was presented at the 5th *Pan Arab Congress of Sexual Health*, on April 20th 2013, Dubai.

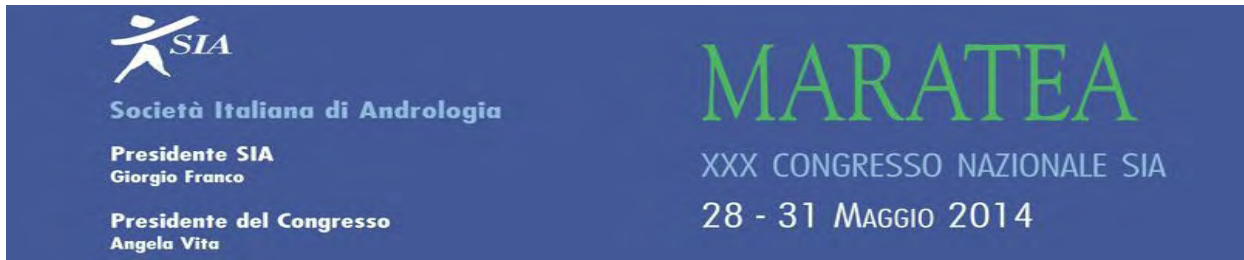

The Effect of Low Intensity Shockwave Therapy on the Erectile Function of Smokers and Non-smokers - Initial Report with a Dedicated System

P. Puppo, A. Casarico

Montallegro Clinic, Genova, Italy

Introduction and Objective

The association between cigarettes smoking and erectile dysfunction (ED) was researched in many studies so far. The strongest relationship found was an adjusted odds ratio of 1.97 for incident ED in smokers compared with nonsmokers. Smoking appears to decrease pelvic and penile vascular flow. Moreover, atherosclerosis is possibly the most important vascular consequence of cigarette smoking. It was established that the effect of smoking on erectile function is related to impairment of endothelium dependent smooth muscle relaxation which is a key process leading to the dilation of vessels in the erectile tissue and an increased blood flow required for erection.

10 years ago, a study that examined the beneficial effects of Shockwaves on ischemia-induced myocardial dysfunction was published and revealed that shockwaves at energy level of $0.09\text{mJ}/\text{mm}^2$ enhance coronary angiogenesis.

The present study examines the effect of a treatment by a new dedicated device delivering shockwaves at the same energy level and a long focal area adjusted to the male sexual organ, on patients suffering from vascular origin ED, both smokers and non-smokers.

Materials and Methods

25 patients with Vasculogenic ED were treated by the shockwave device, 4 times, once a week. 1600 shocks were applied to each Crus and 900 shocks were applied to each Corpus Cavernosum. No PDE5 inhibitors were used during the treatment and 3 weeks prior treatment. Erectile function was evaluated at baseline and at 1, 3 and 6 months post treatment

LSWT – CLINICAL DATA AND REPORTS

by 4 self administered questionnaires: IIEF-6, SEP, GAQ and EHS. Success was defined as positive answers to SEP and GAQ questions, EHS \geq 3 and a significant increase of IIEF-6 score according to the baseline ED severity.

Results

24 men with a mean age of 62.6 have finished treatment. 53% of them were smokers. There was no significant difference between ED duration, age and baseline IIEF-6 of smokers and non-smokers. Co-morbidities rates were higher in smokers than in non-smokers. The increase in IIEF-6 from baseline to the last follow-up was twice as large in the smokers than the non-smokers. **The overall success rate was 70% and 84% of patients answered "Yes" to both GAQ questions.** No adverse events were reported.

Conclusions

This pilot study shows that eventually this new treatment for vascular ED could be suitable to smoking patients and patients with vascular risk factors. More research is required for confirming the efficacy of this treatment on different populations.

The above paper abstract was presented at the 30th Italian society of Andrology Congress (SIA), on May 2014, Maratea, Italy.